

# NOOXS THINK TANK

The free standing room-in-room system offers a simple construction solution for setting up acoustically protected spaces for temporary use. NOOXS Think Tanks are available in four sizes and are comprised of NOOXS wall panels and glass elements, which provide a clear view inside and out. Optional curtains and blinds can also be added to offer privacy when required. A technical ceiling panel with fully integrated LED lighting and ventilation spans the

room, while the remaining ceiling infill can be fitted with additional noise protection. NOOXS Think Tanks are distinguished by the highest standards of comfort in terms of furnishings, a complete technical infrastructure, excellent noise reduction and an extremely economical assembly time. Options for use are varied, ultimately the furniture determines the function. Meeting room, stand-up meeting, Business Box or Phone Booth - anything is possible.

**Design: PearsonLloyd**



## PRODUCT DESCRIPTION

### NOOXS THINK TANK

- 1 Ceiling element
- 2 Wall element
- 3 Technical element
- 4 Glass element
- 5 Hinged door
- 6 Crossbar (open)

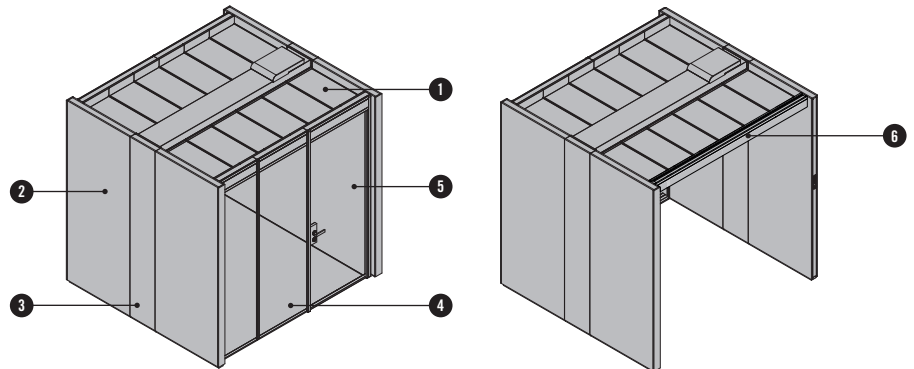

### CEILING ELEMENT

- 1 Ceiling panel  
Steel, powder-coated, white RAL 9010
- 2 Joint profile
- 3 Ceilings - technical element  
Steel, powder-coated, anthracite RAL 7021  
Extension with additional loads (e.g., lights up to 10kg are permitted)  
Walking on the roof is not advised.
- 4 Sound protection hood

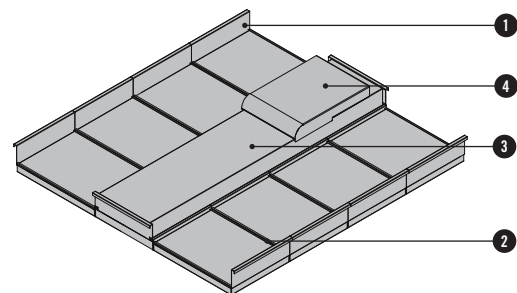

### WALL ELEMENT

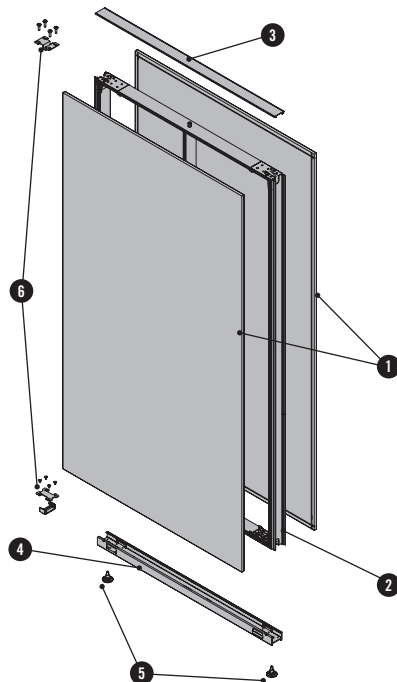

- 1 Panelling – Wall element  
16 mm chipboard  
8 mm chipboard + 8 mm fibre board<sup>1</sup>  
16 mm chipboard with sound-absorbing acoustic filling<sup>2</sup>
- 1 Panelling – Technical element  
16 mm chipboard  
8 mm chipboard + 6 mm fibre board<sup>1</sup>
- 2 Frame – Wall element  
19 mm chipboard/plastic
- 2 Frame – Technical element aluminium
- 3 Cover profile aluminium
- 4 Base profile aluminium
- 5 Adjustment legs  
plastic, can be levelled up to +35 mm
- 6 Extension fittings steel
- 7 Hook-in clip plastic

### TECHNICAL ELEMENT

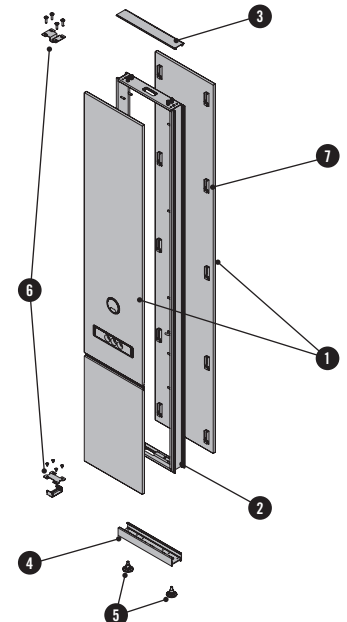

<sup>1</sup> pinnable

Different panelling can be selected on front 1 and front 2. As many as 2 shells on each front are possible (technical element). In the standard version of the wall element, the panelling is permanently glued on.

<sup>2</sup> Sound absorption according to ISO 11654

Rated sound absorption level  $\alpha_w$  0.80 (in acoustically activated areas), Absorption class = B

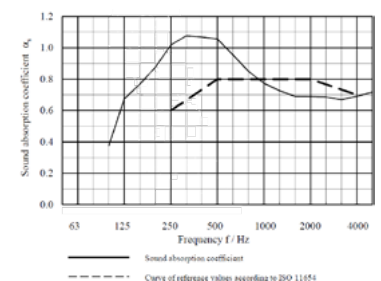

## PRODUCT DESCRIPTION

### GLASS ELEMENT

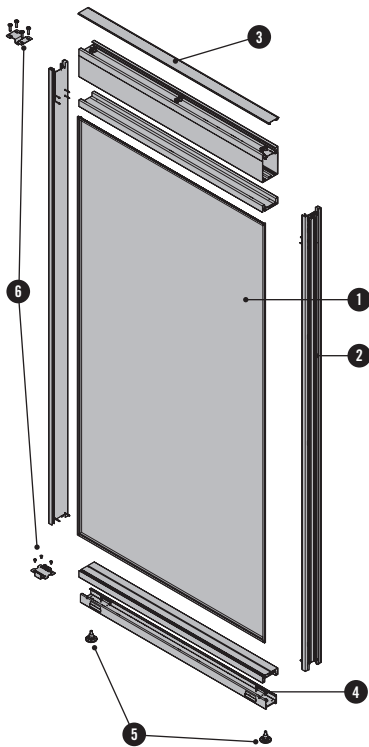

- 1 Surface - glass element**  
Glass 8 mm LSG made of float glass with acoustic film  
Glass 6 mm TSG safety glass  
Clear glass (KS)
- 1 Surface - hinged door**  
10 mm TSG, clear glass (KS)  
10 mm TVG acoustics
- 2 Glass profile - glass element**  
aluminium
- 2 Frame profile - hinged door**  
aluminium
- 3 Cover profile** aluminium
- 4 Base profile** aluminium
- 5 Adjustment legs**  
plastic, can be levelled up to +35 mm
- 6 Extension fittings** steel
- 7 Transitioning rail** steel

### HINGED DOOR

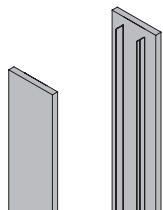
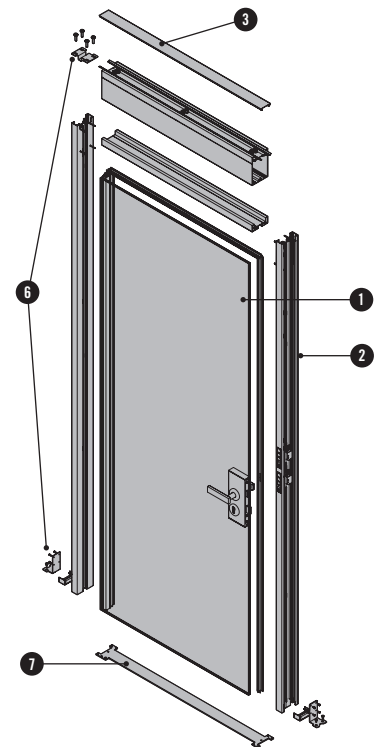

### END PANEL

The end panel is a separate item that must be ordered separately for each free end of a NOOXS arrangement.  
Material: 12 mm chipboard on aluminium profile.

### PANELLING OF TECHNICAL ELEMENTS

Due to the construction of the ceiling element, the panelling on the outside and at deviated panels, also the lower panels on the inner side of the NOOXS Think Tank can be unhooked, to exchange them or to wire them later. The technical element can be divided at each front with a horizontal 20 mm joint. Cables can be fed through the joint.

The joint can be implemented at 2 fixed heights:

- seating height, joint height 655 mm
- standing height, joint height 985 mm

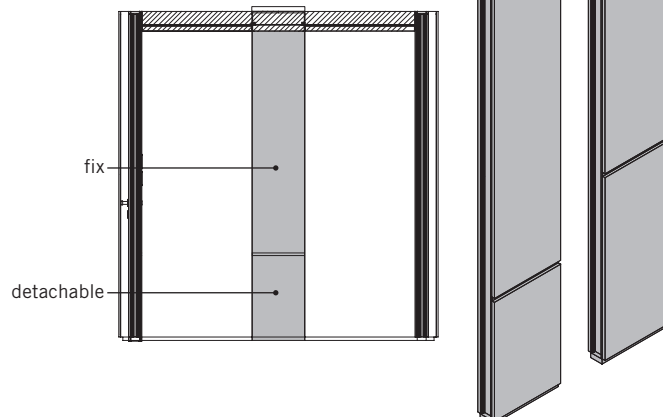

## PRODUCT DESCRIPTION

### ACOUSTIC VERSIONS

Standard:

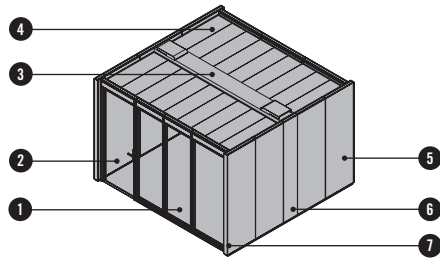

- ① **Glass element:** 6 mm TSG glazing
- ② **Glass door:** 10 mm TSG glazing
- ③ **Ceilings - technical element**
- ④ **Ceiling panel**
- ⑤ **Wall element**
- ⑥ **Technical element**
- ⑦ **Wall termination**

Acoustic level: up to 32 dB  $R_w$   
sound insulation (sound permeability)

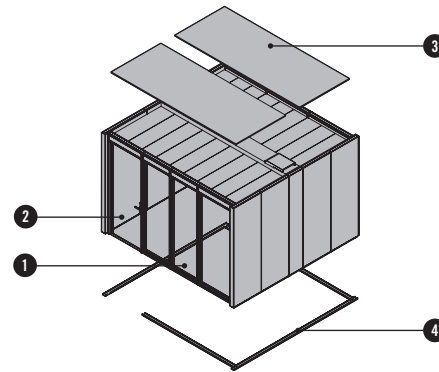

- ① **Glass element:** 8 mm LSG acoustic glass
- ② **Glass door:** 10 mm TSG glazing and drop-down seal
- ③ **Ceiling element with acoustic panels**
- ④ **Acoustic base**

The sound insulation values listed here were determined in accordance with (ÖNORM, DIN) EN ISO 140-3 standards and describe the sound-absorption quality of the dividing wall system tested. Sound insulation for each room depends on the sound-absorption qualities of the built-in dividing wall system and the sound-absorption characteristics of the adjacent structural components. Accompanying components (e.g., bulkheads in floor), on-site connections that are not sealed, as well as their penetrations (ventilation, water, and electrical installations) that do not have the necessary noise reduction level significantly reduce the noise reduction level from one room to the next. Bene GmbH therefore explicitly notes that it does not offer a guarantee for noise reduction from one room to the next once the system is built in.

### CONTROL

#### NOOXS Think Tank "open"

Light control  
Position: Cover right outside

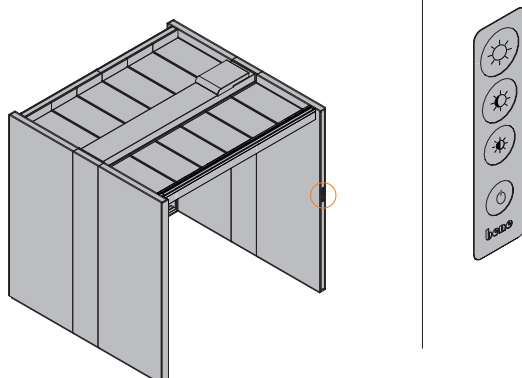

#### NOOXS Think Tank "closed"

Light control and fan control  
Position: Hinged door, door frame inner side

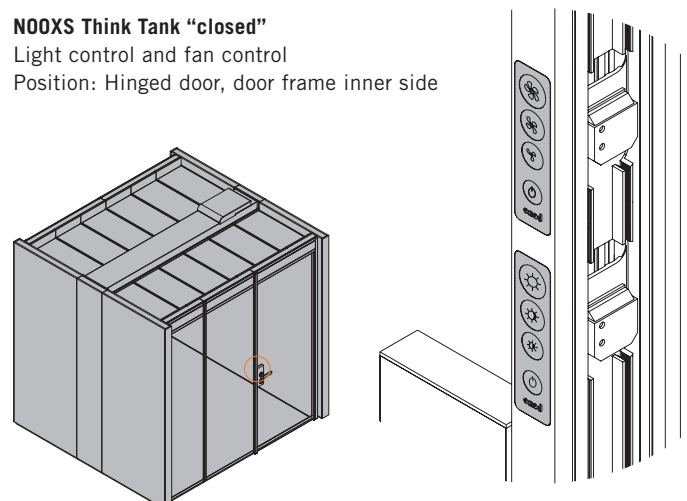

## PRODUCT DESCRIPTION

### VENTILATION SYSTEM

approx. 180 m<sup>3</sup>/h max.  
90 x air exchange/h max.

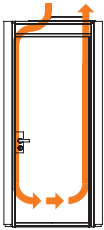

approx. 360 m<sup>3</sup>/h max.  
65 x air exchange/h max.

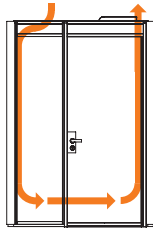

approx. 360 m<sup>3</sup>/h max.  
31 x air exchange/h max.

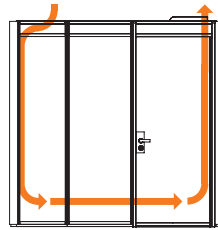

approx. 720 m<sup>3</sup>/h max.  
26 x air exchange/h max.

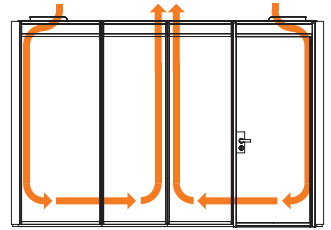

**Characteristics:** adjustable at 3 levels

### LIGHTING

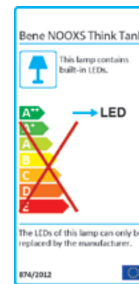
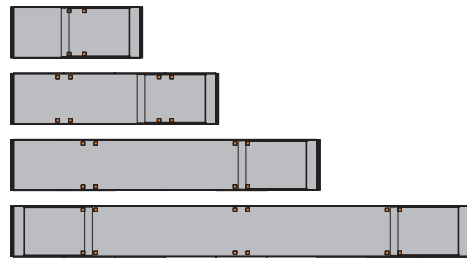
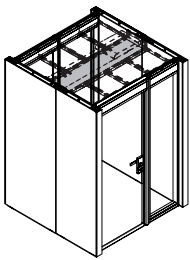

**Note:** by changing the NOOXS Think Tank height, the illumination of the room also changes.

**Characteristics:** 4/8/12 LED lights (9 Watt), colour temperature approx. 3.500 K, dimmable at 3 levels

### SPRINKLER FEED-THROUGH

If necessary, sprinkler systems can be guided through the ceiling technical element at pre-defined positions.

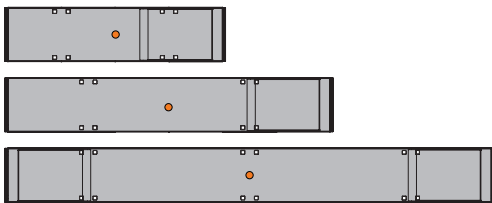

### CABLING DIAGRAM

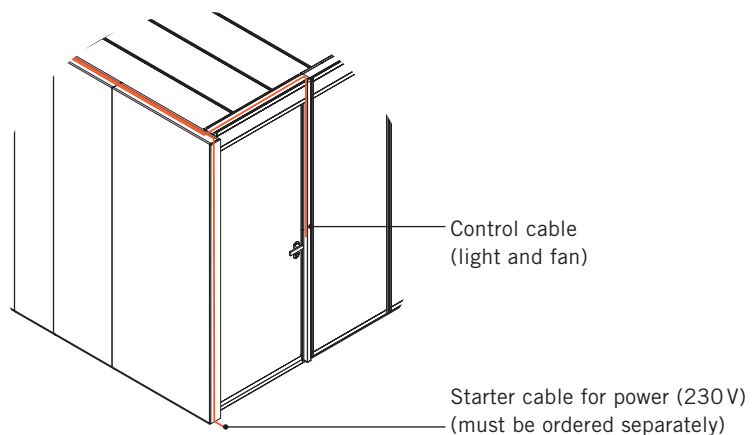
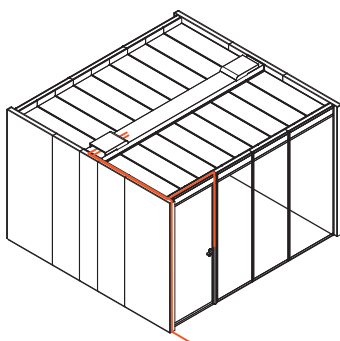

## OVERVIEW & DIMENSIONS

Minimum room height (building) = highest NOOXS element + 300 mm.  
 max. interior height: 2.500 mm, max. exterior height: 2.650 mm (incl. ventilation and lighting)  
<sup>1</sup> Position presence detector (optional selection, see chapter "options" for details)

Wall element	Technical element	Glass element	Crossbar
W: 600, 800, 1.000, 1.200	400	600, 800, 1.000, 1.200	1.603, 2.403, 3.603
D: 100	100	100	97
H: 2.200-2.650	2.200-2.650	2.200-2.650	150

**Measurements in mm**

### Planning note

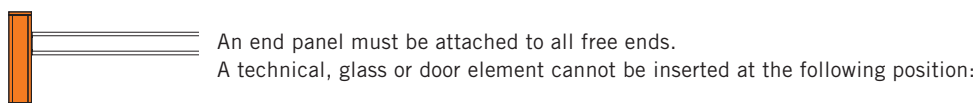
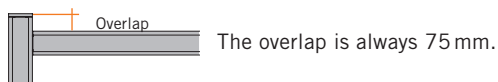

Note: please be aware that there is additional assembly work when you combine several Think Tanks in an order.

### Possible door opening directions

Opening directions "inward" and "outward" permissible.

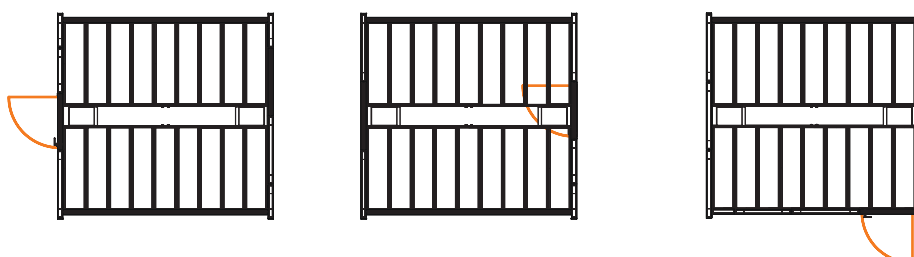

## OPTIONS

### PRESENCE DETECTOR WITH A DELAYED CONTROL UNIT

Lighting and ventilation are automatically activated when anyone enters the Think Tank (Level 2). The user retains the option of controlling the lighting and ventilation according to his or her needs. When the user exits the Think Tank, the delayed control unit (included) becomes active: the lighting is automatically shut off and the ventilation activated for ten minutes. This prepares the NOOXS Think Tank optimally for the next user. The Think Tank can be retrofitted with a presence detector at any time.

Note: Heat sources such as printers can lead to malfunctions, so they and similar devices should be positioned outside the Think Tank. Possible positions see chapter „overview & dimensions“.

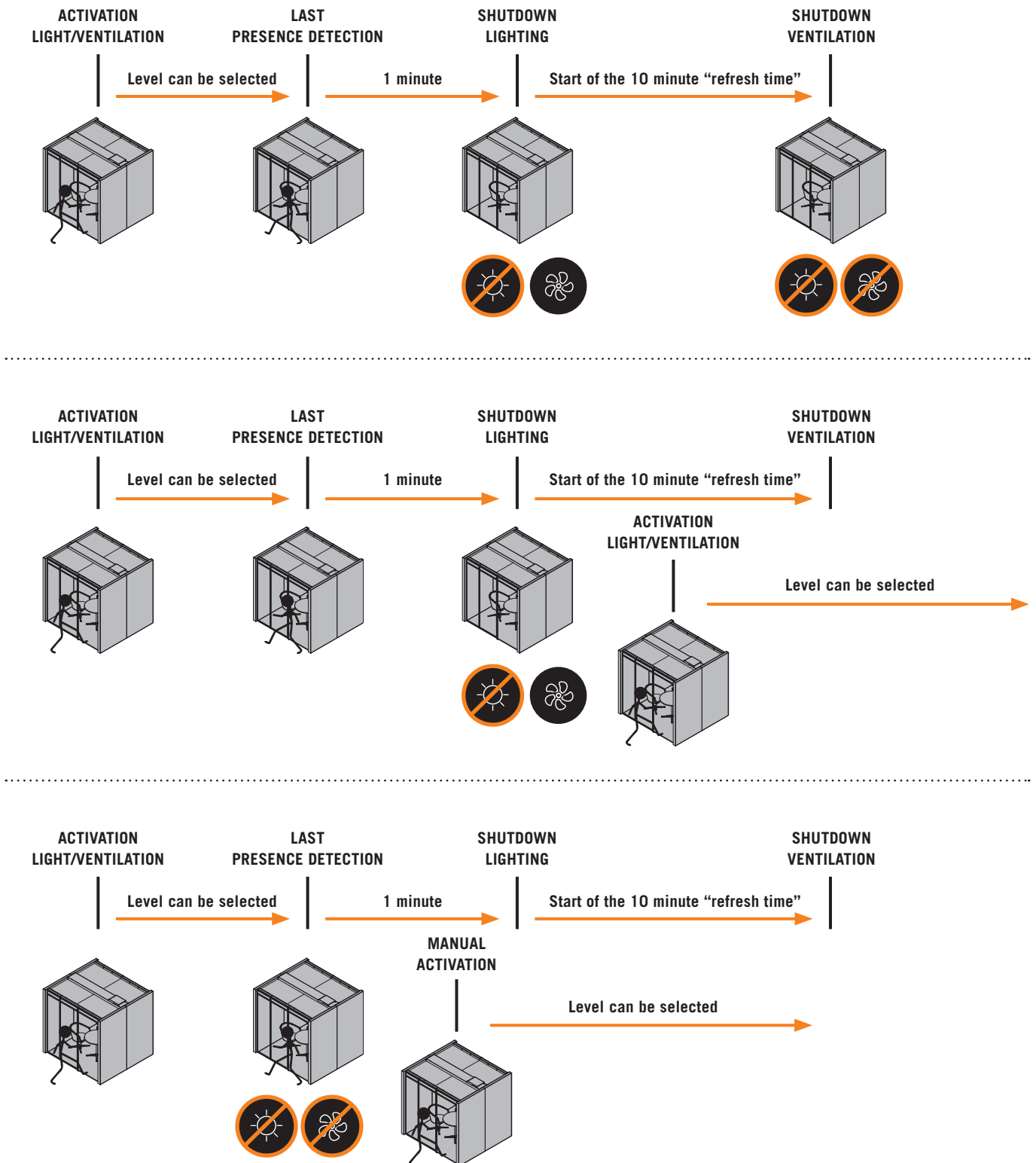

## OPTIONS

### PREPARATION FOR CONNECTION PLUG BOARD (TECHNICAL ELEMENT)

A cut-out for a connection plug board (Bene 4-fold connection plug board) can be configured in the panelling for additional cabling - this must be ordered separately.

The cut-out can be implemented at 2 fixed heights:

- Seating height, 830 mm high
- Standing height, 1.160 mm high

If the panelling is divided with a joint, then the permissible position for the cut-out is determined by the position of the joint.

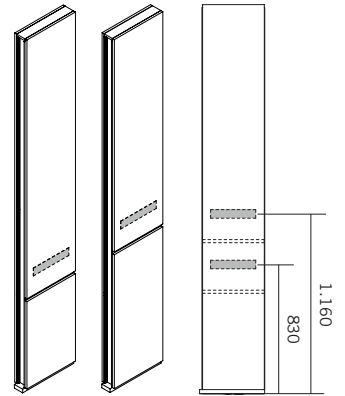

### CABLE OUTLET FOR SCREEN (TECHNICAL ELEMENT)

For additional cabling purposes a cable outlet can be configured in the panelling for cabling or assembly of a screen.

The cable outlet can be implemented at 2 fixed heights:

- Seating height, 1.040 mm high
- Standing height, 1.370 mm high

If the panelling is divided with a joint, then the permissible position for the cable outlet is determined by the position of the joint. If there is a cut-out for a connection plug board, then the same position designation also applies to the cable outlet.

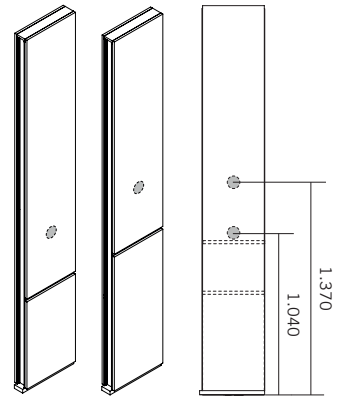

### SCREEN ASSEMBLY (TECHNICAL ELEMENT)

The following are required in order to assemble a screen:

- NOOXS assembly set for TFT wall-mounted bracket
- "SMS Func Flatscreen WM T" wall-mounted bracket
- a screen compatible with the wall-mounted bracket, e.g. "NEC MultiSync LCD V484"
- 1 connection plug board with 3 power sockets
- 1 starter cable

The wall-mounted bracket is only compatible with the 400 mm NOOXS technical element.

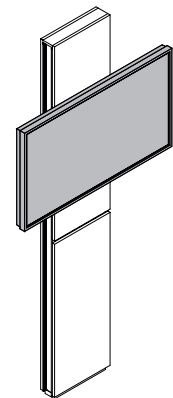

### PHONE BOX TABLE

Table made of plywood 25 mm. Direction of top shape left or right.  
Dimensions: Width: 1.002 mm, depth: 349 mm and height: 129 mm  
Maximum load: 10 kg

Colours based on the Bene collection in melamine groups 1, 2 and 3.

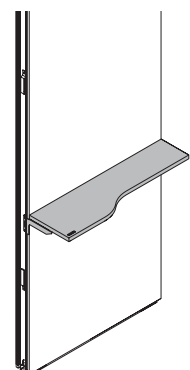



## OPTIONS

### BUILT-IN COMPONENTS IN GLASS ELEMENT

It is possible to fit out the NOOXS glass elements with additional modules in order to create privacy; upgrading with these modules is also possible.

#### Slats

Hidden integration directly in the NOOXS Think Tank glass element.  
Clearance angle of the slats: 45°

Colours & materials Melamine groups 1-3

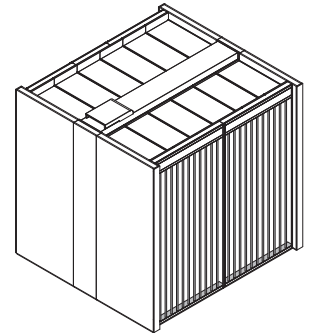

#### Curtain by Silent Gliss

Hidden integration directly in the NOOXS Think Tank glass element or, for the open version, in the ceiling bar. Available height: 2500mm.

Possible fabric collections:

- Someo
- Colorama® 2

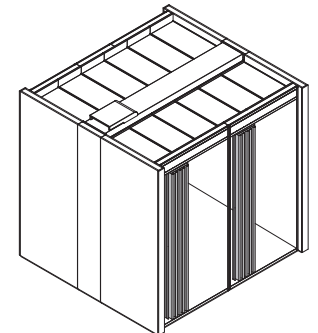

---

### NOOXS PROJECTION SCREEN

For preparation of the NOOXS wall elements for IDEA WALL projections. The projection screen is available for 1 projector (width 2.000mm). Height 2.500mm. The projection screen (chipboard panel in MW white melamine) is fastened to the top of the NOOXS wall element with two steel cables and mounting brackets. One mounting plate is also supplied.

**Attention:** The NOOXS projection screen can only be mounted on the outside of the Think Tank. For assembly reasons, it is important that the surface of the NOOXS wall elements behind the projection screen not be made of "fabric".

The matching projector must be ordered separately (e.g. NEC U321H).

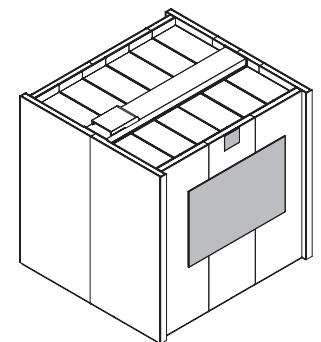

---

### NOOXS WHITEBOARD

The following are required in order to assemble a whiteboard:

- NOOXS assembly set for whiteboard
- e.g., Abstracta whiteboard "Moow"

The whiteboard is attached at the top of the NOOXS wall element by using one or two steel cables and mounting brackets. Whiteboards  $\leq 1.200$  mm require 1 vertical joint. Whiteboards between 1.500 to  $\leq 2.000$  mm require 2 vertical joints.

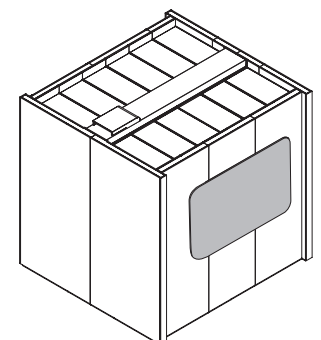

## INSPIRATIONS

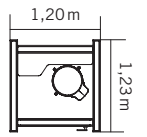

Inspiration #01

Phone Box Setting  
Area: 1,48 m<sup>2</sup>

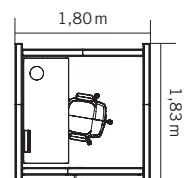

Inspiration #02

Business Setting  
Area: 3,29 m<sup>2</sup>

## INSPIRATIONS

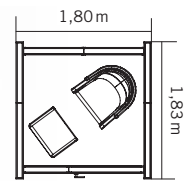

Inspiration #03

Focus Setting  
Area: 3,29 m<sup>2</sup>

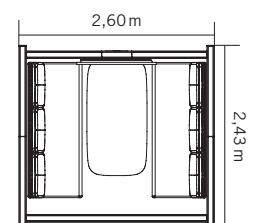

Inspiration #04

Open Focus Setting  
Area: 6,32 m<sup>2</sup>

## INSPIRATIONS

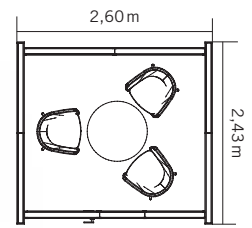

Inspiration #05

Meeting Setting  
Area: 6,32 m<sup>2</sup>

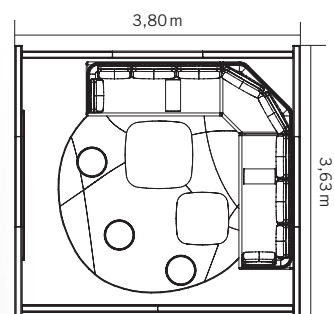

Inspiration #06

Open Lounge Setting  
Area: 13,79 m<sup>2</sup>

## INSPIRATIONS

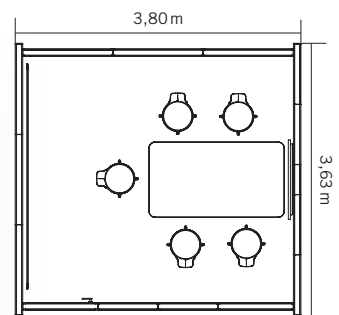

Inspiration #07

High Working Setting  
Area: 13,79 m<sup>2</sup>

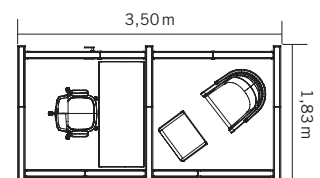

Inspiration #08

Double Setting  
Area: 6,40 m<sup>2</sup>

## COLOURS & MATERIALS

### MELAMINE: Basic colours

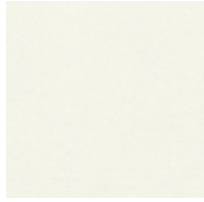

MW white

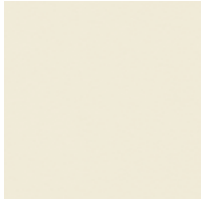

MQ office white

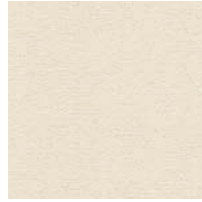

MC canvas

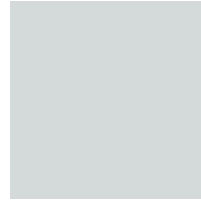

MP platinum



TM clay

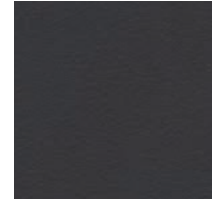

MT anthracite



MA aluminium



MS slate

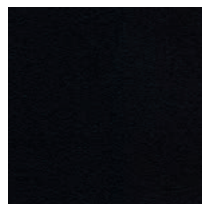

MB basalt

### MELAMINE: Additional basic colours

### MELAMINE: Décor colours

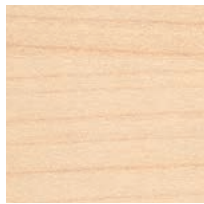

AR maple

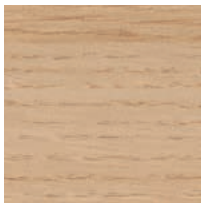

EI oak

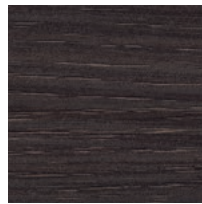

EC oak moreda

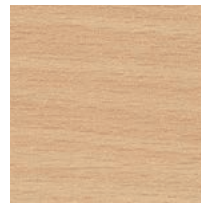

BH beech, light



NG walnut grey

### MELAMINE: Décor colours with texture



CE elm, white



CO coco

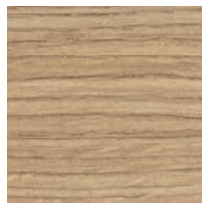

EA oak aragon

### MELAMINE: Accent colours



TX mustard



TH marino blue



TS fern green

## COLOURS & MATERIALS

### VENEER: Maple

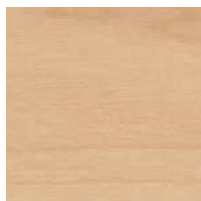

AK canad. maple

### VENEER: Beech



BG beech, grey

### VENEER: Oak

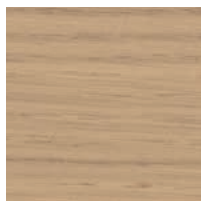

EY oak, silt

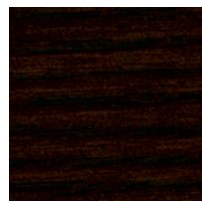

ER oak, amaretto

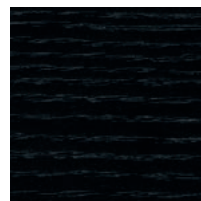

EV oak, volcano



EG oak grey

### VENEER: Chestnut

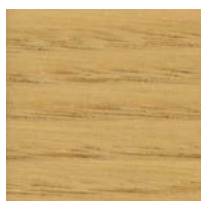

KD chestnut natural

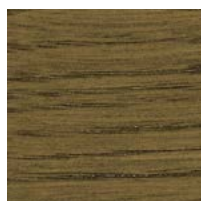

KP chestnut brown



KQ chestnut grey

### VENEER: Walnut

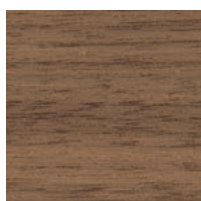

NF americ. walnut

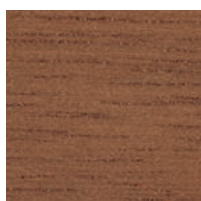

NR walnut, sienna

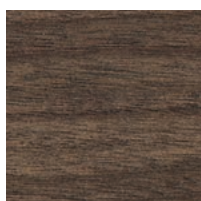

NB walnut, umbra

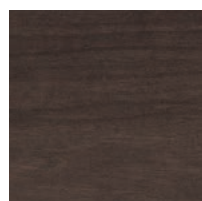

NA wal., anthracite

### VENEER: Bamboo

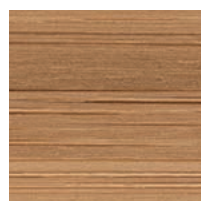

BJ bamboo

### MDF SURFACES: Varnished, solid-coloured plastic

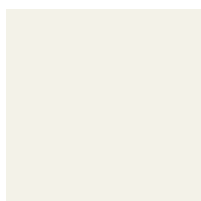

WI white

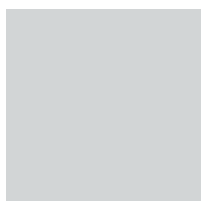

PL platinum

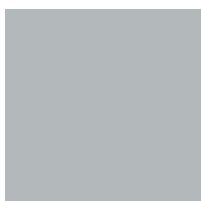

AM aluminium



SR slate



AT anthracite



BS basalt

### METAL SURFACE: Metal surface, powder-coated

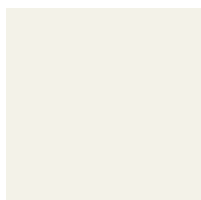

WI white

### GLASS

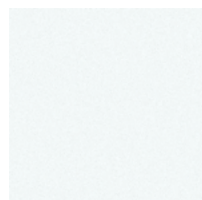

KS clear glass

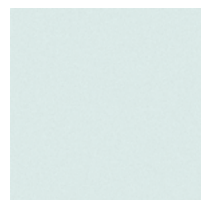

ST white, satin finish

All fabric collections are available as cover: Urban Plus, Xtreme Plus, Inn, Step, Step Melange, Patina, Remix, Europost, Clara, Mainline Flax, Divina, Steelcut, Fiord, Hallingdal, Steelcut Trio, Divina Melange, Divina MD, Greenwich, Greenwich Uni. More information about the specific fabric collections is available at [www.bene.com](http://www.bene.com).

## BENE WORKS SUSTAINABLY

Bene plays a leading role in responsible environmental management. It is practised throughout all company divisions – from product development, procurement, production and logistics to product recycling. Bene considers ecology to be a central element of its responsible and sustainable corporate strategy. Bene sees the legal regulations as minimum requirements and strives for better and more sustainable environmental protection throughout the group. The Bene principle in environmental policy is: **Avoidance – Minimisation – Recycling – Disposal.**

### NOOXs THINK TANK - ECOLOGICAL STANDARDS

- 98,2% recyclable
- 55,6% renewable raw materials
- 58,66% use of recycled product materials (33,88% post-consumer, 24,78%, pre-consumer)
- 46,27% use of recycled product materials that comply with LEED (33,88% post-consumer, 24,78%, pre-consumer)
- Resource-conserving product design
- Use of certified wood (chain of custody)
- Use of materials tested for presence of hazardous substances
- No PVC, chromium, lead or mercury used
- Individual parts can be sorted according to homogeneous categories
- Recyclable, with a positive contribution to the carbon footprint (average 1.105,7 kg CO<sub>2</sub>)

## NOOXs THINK TANK LEED POINTS

Leadership in Energy and Environmental Design (LEED) is a system developed by the U.S. Green Building Council to classify ecological construction. As an internationally recognised standard, LEED sets out numerous guidelines for environmentally friendly, resource-efficient, and sustainable construction. The use of NOOXs Think Tank is an important contribution to LEED certification. The following criteria for this are from “LEED 2009 for Commercial Interiors”:

MR Credit 4	Recycling share	up to 2 points
MR Credit 5	Regional materials	up to 2 points
MR Credit 7	Certified wood	up to 1 point
IEQ Credit 4.5	Material with low hazardous substance content	up to 1 point

### NOOXs THINK TANK MATERIAL COMPONENTS

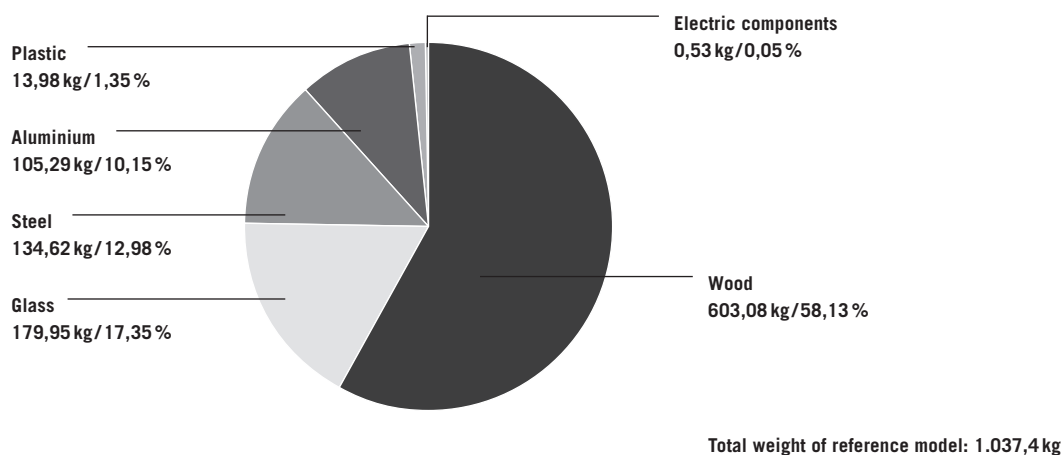

Environment-related information about Bene: [www.bene.com / sustainability](http://www.bene.com/sustainability)